

分水过滤器能过滤空气中的液态油、冷凝水及杂质，对于特殊应用场合，5μm滤芯容易替换40μm的标准滤芯。
The OF with water separator cleans the compressed air of fluid oil, condensation and dirt particles, for special application, the standard 40μm filter element may easily be replaced by a 5μm filter element.



订购码/Ordering Code



图形符号/Graphic Symbol



规格/Specification

Filters		MINI			MIDI			MAXI		
40μm	手动放水器 / Manual Drain	OF-1/8-MINI	OF-1/4-MINI	OF-3/8-MINI	OF-3/8-MIDI	OF-1/2-MIDI	OF-3/4-MIDI	OF-3/4-MAXI	OF-1-MAXI	
5μm		OF-1/8-5M-MINI	OF-1/4-5M-MINI	OF-3/8-5M-MINI	OF-3/8-5M-MIDI	OF-1/2-5M-MIDI	OF-3/4-5M-MIDI	OF-3/4-5M-MAXI	OF-1-5M-MAXI	
工作介质 / Medium		压缩空气 / Compressed air								
结构特点 / Features of structure		带水分离器的烧结式过滤器 / Sintered filter with water separator								
安装方式 / Mounting type		管式安装或支架安装 / Pipe mounting or foot mounting								
安装位置 / Assembly position		垂直方向 (Vertical) ±5°								
连接尺寸 / Connection		G1/8"	G1/4"	G3/8"	G3/8"	G1/2"	G3/4"	G3/4"	G1"	
标准额定流量 / Standard nominal flow rate		OF-...	1000	1200	1400	2700	3000	3000	5000	5300
		OF-...-5M	600	950	1100	1800	1900	1900	3200	3300
输入压力 / Primary pressure		手动排水阀 / Manual drain 1~16bar								
过滤精度 / Grade of filtration		40μm/5μm								
最大凝水容量 / Max. condensate capacity		22ml								
温度范围 / Temperature range		0~60℃								
材料 / Materials information		壳体; 压铸锌; 过滤杯和油杯; PC; 金属保护罩; 铝合金; 密封; 丁腈橡胶 Housing: Zinc die-casting; Filter bowl: PC; Metal bowl guard: Aluminium alloy; Sealing: NBR								

外形尺寸/Overall Dimension

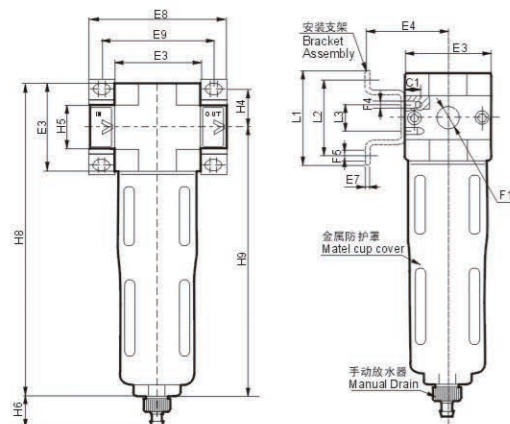

尺寸表/Dimension Sheet

型号 / Model	E3	E4	E7	E8	E9	F1	F4
OF-...-MINI	40	39	2	64	52	G1/8", G1/4", G3/8"	M4
OF-...-MIDI	55	47	3	85	70	G1/8", G1/2", G3/4"	M5
OF-...-MAXI	66	53	3	96, 116	80, 91	G3/4", G1"	M5

型号 / Model	F5 Φ	L1	L2	L3	H4	H5	H6	H8	H9
OF-...-MINI	4.5	44	35	11	17.5	20	15	144	129
OF-...-MIDI	5.5	71	60	22	24.5	32	15	179	156
OF-...-MAXI	5.5	71	60	22	24.5	32, 40	15	203	175

内部结构图/Internal structure

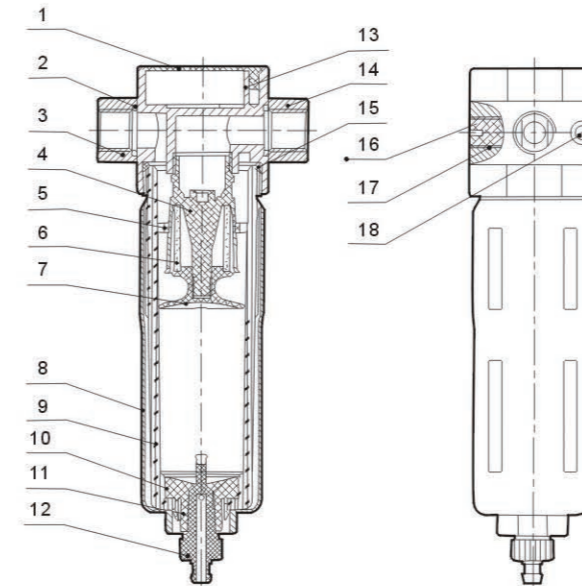

序号 NO	名称 Item	材料 Material
1	装饰盖(圆型) Ornament cover (round)	POM
2	O型圈 O-ring	NBR
3	分气块-IN Flange-IN	锌合金 Zinc alloy
4	滤芯座 Filter element base	POM
5	旋风叶轮 Whirl wind impeller	POM
6	滤芯 Filter element	聚乙烯 PE
7	挡水板 Manger	POM
8	保护罩 Metal bowl guard	铝合金 Aluminium alloy
9	水杯 Filter bowl	PC
10	O型圈 O-ring	NBR
11	内接头 Inner joint	POM
12	放水器 Condensate drain	POM
13	OF 阀体 OF Body	锌合金 Zinc alloy
14	分气块 OUT Flange-OUT	锌合金 Zinc alloy
15	O型圈 O-ring	NBR
16	丝堵 Plug	POM
17	O型圈 O-ring	NBR
18	内六角螺丝 Allen screw	S35C

流量图/Flow diagram

标准额定流量qn和输出压力p2的关系 / Standard flow rate qn as a function of the output pressure p2

